

AMUN 1U Power Supply Unit

DATASHEET

TABLE OF CONTENTS

| | | |
|------------|---|-----------|
| 1 | <i>PRODUCT OVERVIEW</i> | 4 |
| 2 | <i>TECHNICAL SPECIFICATION</i> | 5 |
| 2.1 | SOLAR INPUT SYSTEM | 6 |
| 2.2 | BATTERY MANAGEMENT SYSTEM | 7 |
| 2.3 | POWER DISTRIBUTION SYSTEM | 8 |
| 3 | <i>INTERFACES</i> | 10 |
| 3.1 | ELECTRICAL | 10 |
| 3.1.1 | PC104 stack connector | 10 |
| 3.1.2 | Solar input | 11 |
| 3.1.3 | RBF & DS | 11 |
| 3.1.4 | EGSE | 12 |
| 3.2 | SOFTWARE | 12 |
| 3.3 | MECHANICAL | 13 |
| 4 | <i>DELIVERABLES</i> | 13 |
| 5 | <i>RELATED PRODUCTS</i> | 13 |
| 6 | <i>DISCLAIMER</i> | 14 |

LIST OF FIGURES

Figure 2-1: Amun PSU 1U block diagram 5
 Figure 2-2: Amun PSU 1U interface overview 5
 Figure 2-3: Solar input system of Amun 1U 6
 Figure 2-4: Real world SIS performance example of performance from Planetum-1 mission 7
 Figure 2-5: Battery management system part of Amun 1U..... 7
 Figure 2-6: Power distribution system of AMUN 1U 8
 Figure 2-7: Typical efficiency for selected voltage output..... 9
 Figure 2-8: Relative voltage drop per channel 9
 Figure 3-1: Amun PSU 1U PC104 connector pinout reference 10
 Figure 3-2: PSU solar input connector11
 Figure 3-3: Amun PSU RBF and Deployment switch diagram11
 Figure 3-4: PSU EGSE connector 12
 Figure 3-5: Mechanical interface of the Amun 1U PSU module 13

LIST OF TABLES

Table 2-1: Technical specification..... 6
 Table 2-2: Solar input system technical specification 6
 Table 2-3: Battery management system technical specification..... 7
 Table 2-4: Power distribution system technical specification 8
 Table 3-1: Overview of interfaces 10
 Table 3-2: Solar input connector reference11
 Table 3-3: RBF and DS connector reference.....11
 Table 3-4: EGSE connector reference 12
 Table 4-1: Deliverables 13

GLOSSARY

| | |
|------------------|---|
| CAN | Controller Area Network |
| CSP | Cubesat Space Protocol |
| GND | Ground |
| I ² C | Inter Integrated Circuit |
| IC | Integrated Circuit |
| ICD | Interface Control Document |
| MPPT | Maximum Power Point Tracking |
| PSU | Power Supply Unit |
| RS485 | Differential communication bus type |
| UART | Universal Asynchronous Receiver / Transmitter |
| VCC | Voltage at Common Collector |

1 PRODUCT OVERVIEW

The Amun is a power supply unit (PSU) for 1U class nanosatellites integrated in PC104 form factor. In just 0.2 U format, it provides the whole power supply chain starting with MPPT solar input system, through battery management system and up to regulated DC/DC converters branched into 6 controllable regulated channels and one battery voltage output channel.

The module consists of two printed circuit boards -The Solar Input System add-on board and the main board containing housing regulation, output control and protection, and communication interfaces.

Flight heritage on 10+ missions (e.g. LASARsat, CroCube, GRBBeta and external customers).

2 TECHNICAL SPECIFICATION

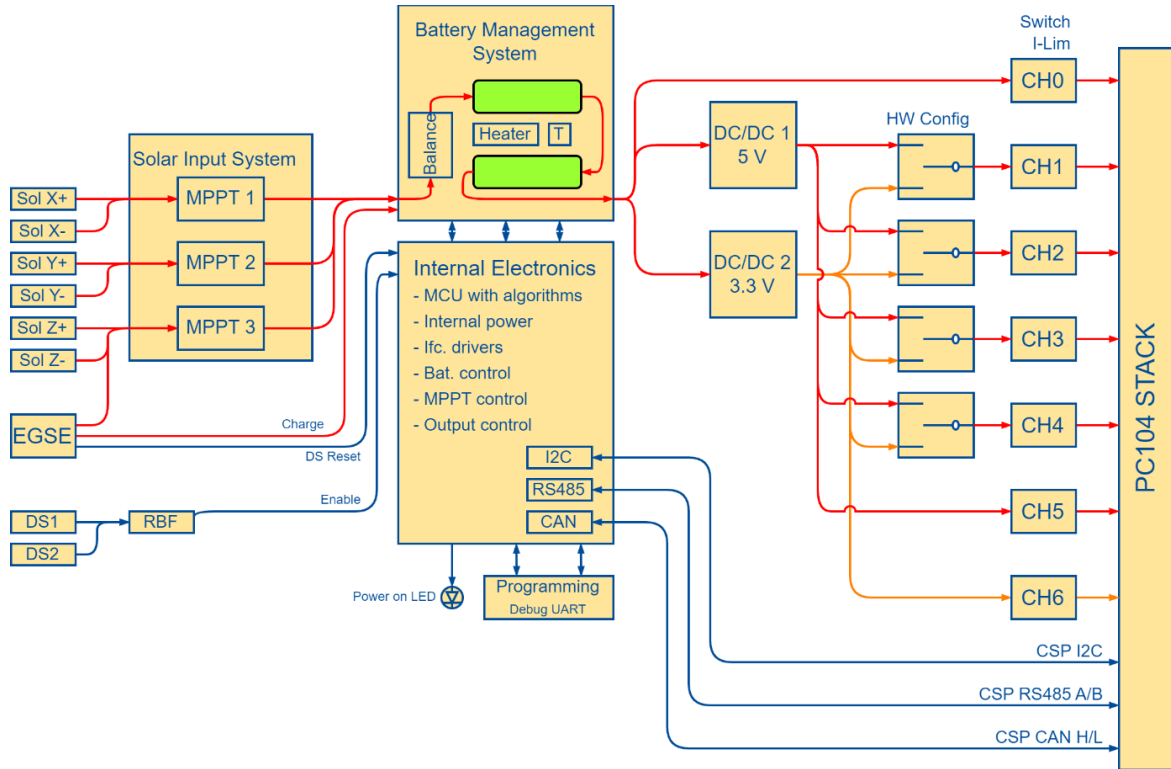

Figure 2-1: Amun PSU IU block diagram

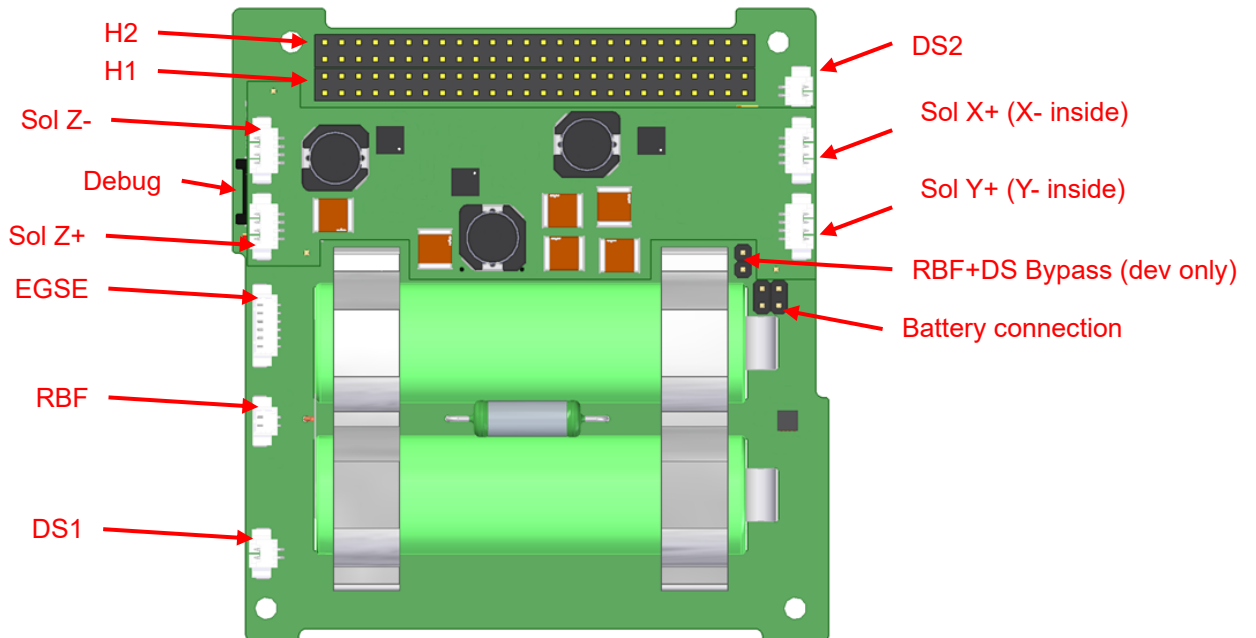

Figure 2-2: Amun PSU IU interface overview

Table 2-1: Technical specification

| Parameter | Value | Unit |
|---------------------------------------|---|------|
| Operating Temperature | -40 to +85 | °C |
| Dimensions | 90.2 x 95.9 x 19.7 PC104 | mm |
| Mass | 185 | g |
| Solar input | 5 V @ 500 mA | |
| Power outputs | 1x VBAT 1x 3.3 1x 5 4x 3.3/5 conf. | V |
| Battery configuration | 2S1P | |
| Battery capacity | 24 | Wh |
| Battery voltage | typ. 7.2 max. 8.2 | V |
| Reported data over software interface | Uptime Battery voltage Current draws Battery current in/out Solar input V/A/P | |

2.1 SOLAR INPUT SYSTEM

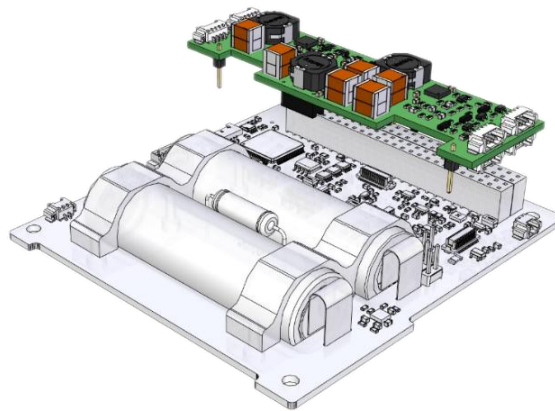

Figure 2-3: Solar input system of Amun 1U

Table 2-2: Solar input system technical specification

| Parameter | Value | Unit |
|---------------------------|-------|------|
| MPPT regulator channels | 3 | |
| Inputs per MPPT regulator | 2 | |
| Maximum input voltage | 5.5 | V |
| Maximum input current | 550 | mA |
| Efficiency | 73 | % |

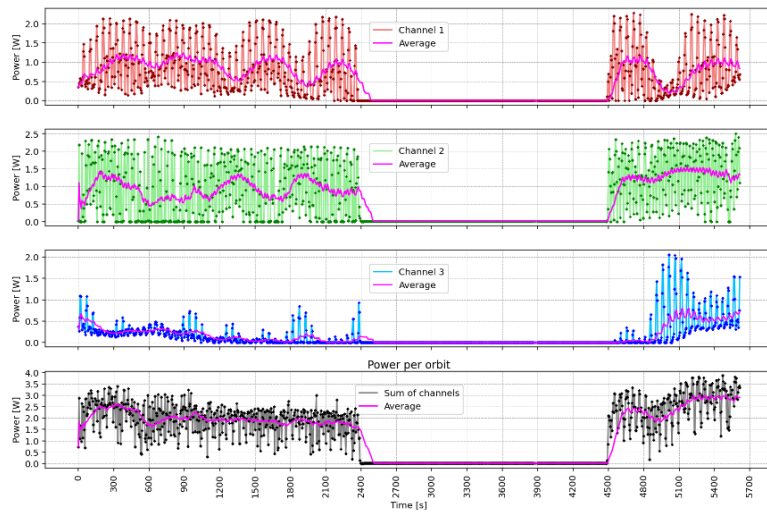

Figure 2-4: Real world SIS performance example of performance from Planetum-1 mission

The example in Figure 2-4 presents data from real-world measurement on Planetum-1 1U CubeSat for 1 orbit (LEO SSO). The satellite was in a random tumbling state. You can see the sunlit and eclipse times of the orbit. The data dispersion is caused by irregular measurement and the MPPT algorithm.

2.2 BATTERY MANAGEMENT SYSTEM

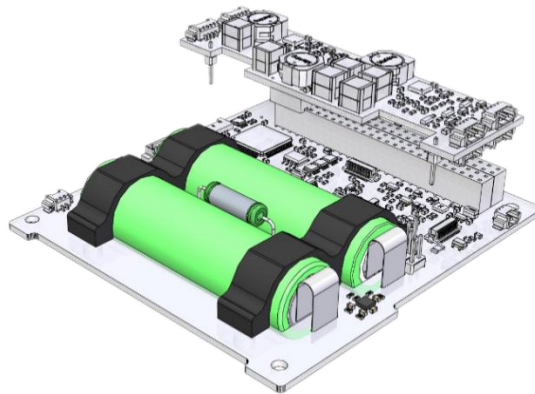

Figure 2-5: Battery management system part of Amun 1U

Table 2-3: Battery management system technical specification

| Parameter | Value | Unit |
|---------------------------------|---------------------|------|
| Battery type | NCR18650B | |
| Typ. battery pack voltage | 7.2 | V |
| Typ. battery pack capacity | 24 | Wh |
| Max. combined discharge current | 6 | A |
| Battery balancing | Dedicated IC | |
| Battery temperature | Dedicated sensor | |
| Battery heater | Manual or automatic | |

2.3 POWER DISTRIBUTION SYSTEM

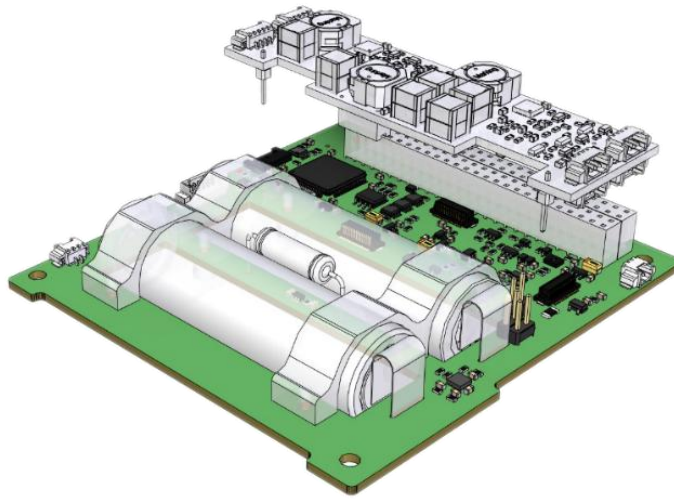

Figure 2-6: Power distribution system of AMUN 1U

Table 2-4: Power distribution system technical specification

| Parameter | Value | Unit |
|--|---|----------------------|
| Regulators | 1x 3.3 1x 5 | V |
| Power outputs | 1x 3.3 (fixed) 1x 5 (fixed) 4x 3.3/5 (conf.) 1x VBAT | V |
| Typ. power output stability | 50 | mV (peak to peak) |
| Max. current draw per output | 4 | A |
| Max. combined current per regulator | 6 | A |
| Recommended max current draw per channel | 1.5 | A |
| Ty. 3.3 V self-consumption | 0.155 | mW |
| Ty. 5 V self-consumption | 0.149 | mW |

All power outputs implement a power switch to control their on and off states.

The typical efficiencies of Amun at selected voltage levels are shown in Figure 2-7. These efficiencies were measured from the charged battery to the corresponding PC104 stack connector pin, encompassing all losses in the power path.

Figure 2-8 shows the typical voltage drop of each power output channel as a result of series resistance of the hardware implementation.

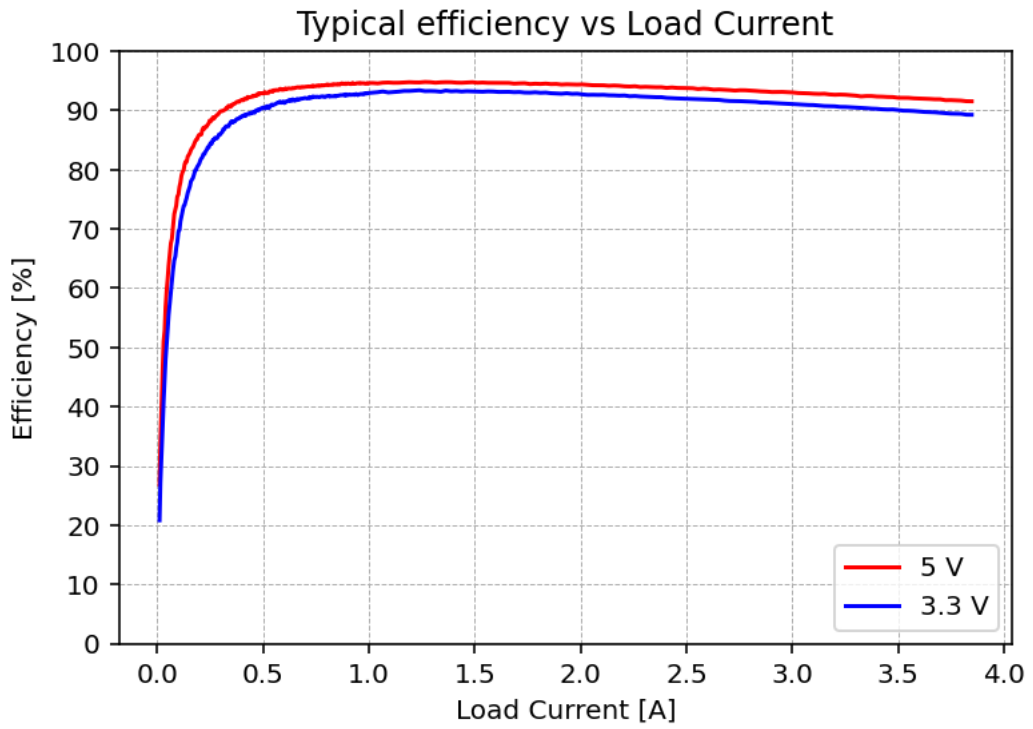

Figure 2-7: Typical efficiency for selected voltage output

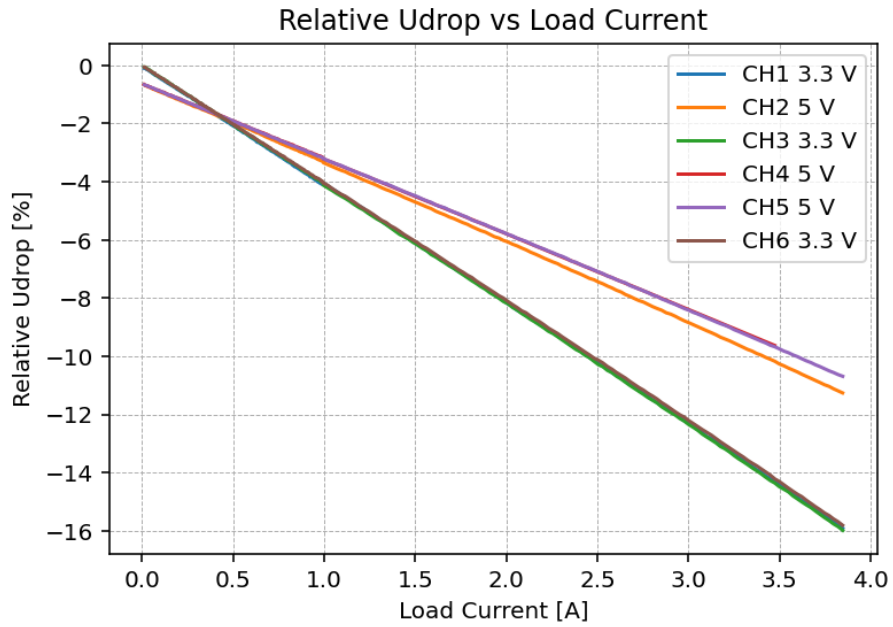

Figure 2-8: Relative voltage drop per channel

3 INTERFACES

Table 3-1: Overview of interfaces

| Interface | Description |
|----------------------|--|
| UART Debug | Typically implements plain text CLI. |
| CSP I ² C | CSP over I ² C bus. Speed up to 400 kHz |
| CSP RS485 | CSP over RS485 KISS. Speed up to 38400 Baud rate. |
| CSP CAN | CSP over CAN. Speed up to 1 Mbit/s |
| Solar input | Input from solar panel (5 V @ 500 mA) |
| EGSE | Electronic Ground Support Equipment (DS Reset, Charging) |
| RBF | Remove Before Flight |
| DS1, DS2 | Deployment switches for activation |

3.1 ELECTRICAL

3.1.1 PC104 stack connector

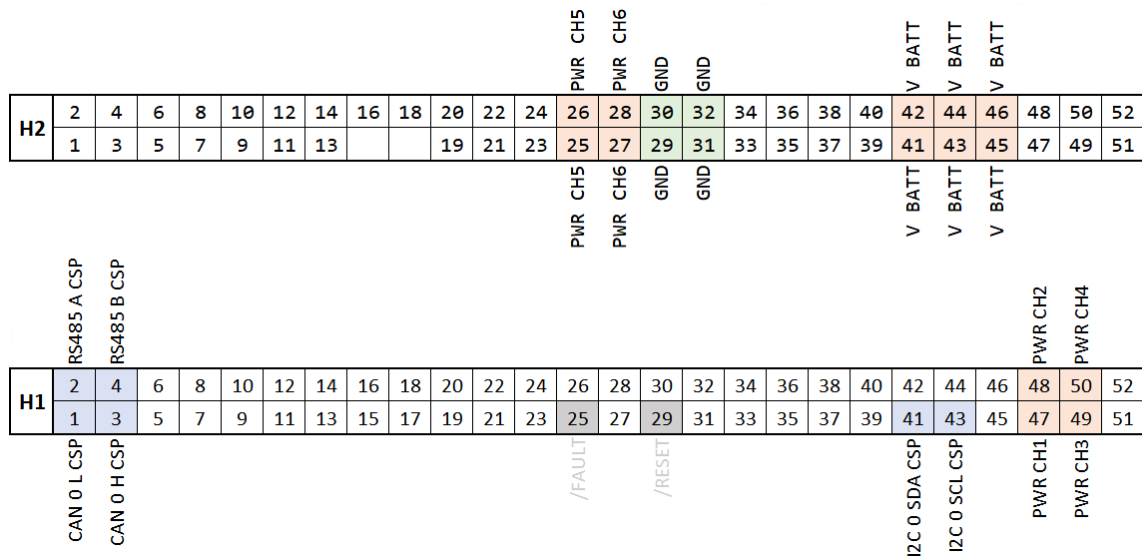

Figure 3-1: Amun PSU 1U PC104 connector pinout reference

The connector typically used is SAMTEC SSQ-126-03-G-D. Customization of the connector type is available on special request at order.

3.1.2 Solar input

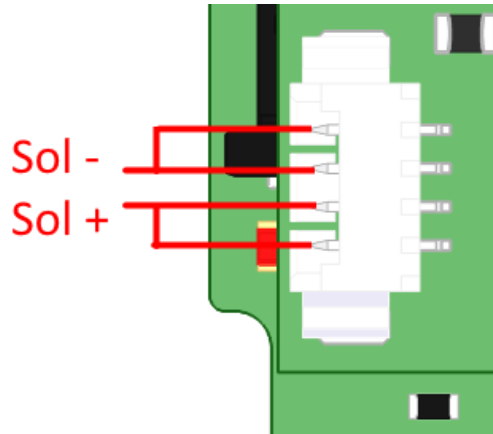

Figure 3-2: PSU solar input connector

Table 3-2: Solar input connector reference

| Connector | Connector type |
|--------------------|--|
| On module | Molex PicoBlade 53261-0471 |
| Mates with (cable) | Molex PicoBlade 51021-0400 (crimp housing) |

3.1.3 RBF & DS

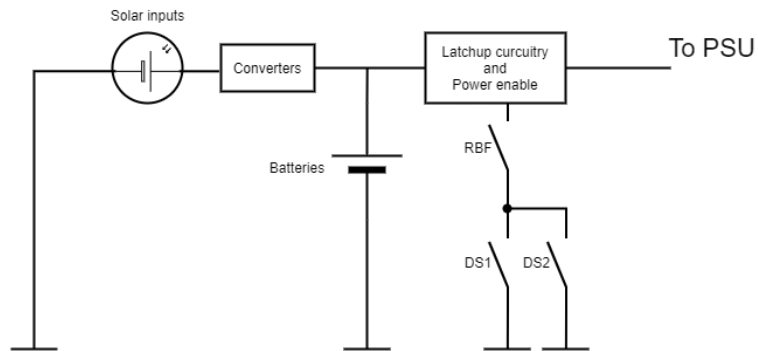

Figure 3-3: Amun PSU RBF and Deployment switch diagram

Once turned on, the PSU enters a latch-up state. To turn PSU off, DS and RBF have to be deactivated first. Then DS Reset on the EGSE connector needs to be connected to Ground.

Table 3-3: RBF and DS connector reference

| Connector | Type |
|--------------------|--|
| On module | Molex PicoBlade 53261-0271 |
| Mates with (cable) | Molex PicoBlade 51021-0200 (crimp housing) |

3.1.4 EGSE

The PSU unit includes a connection for Electrical Ground Support Equipment (EGSE) that includes charging and interface to turn the PSU off.

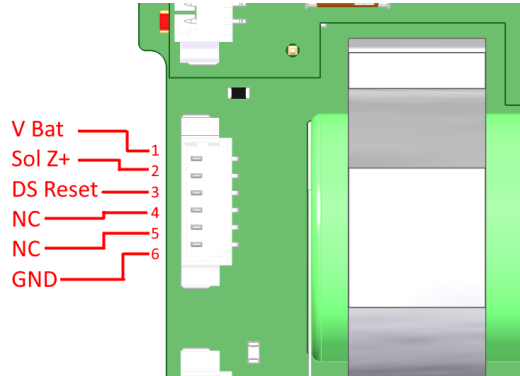

Figure 3-4: PSU EGSE connector

Table 3-4: EGSE connector reference

| Connector | Type |
|--------------------|--|
| On module | Molex PicoBlade 53398-0671 |
| Mates with (cable) | Molex PicoBlade 51021-0600 (crimp housing) |

3.2 SOFTWARE

The Amun 1U PSU module implements CSP v1 as the main communication protocol on its RS485, CAN and I²C interfaces. The CSP address is always the same as the I²C slave address. Additionally, the module includes a command line interface (CLI) for operation and configuration available over debug UART and as a CSP service. For software support and development support contact Spacemanic directly.

3.3 MECHANICAL

The PSU is designed for PC104 format interface compatibility.

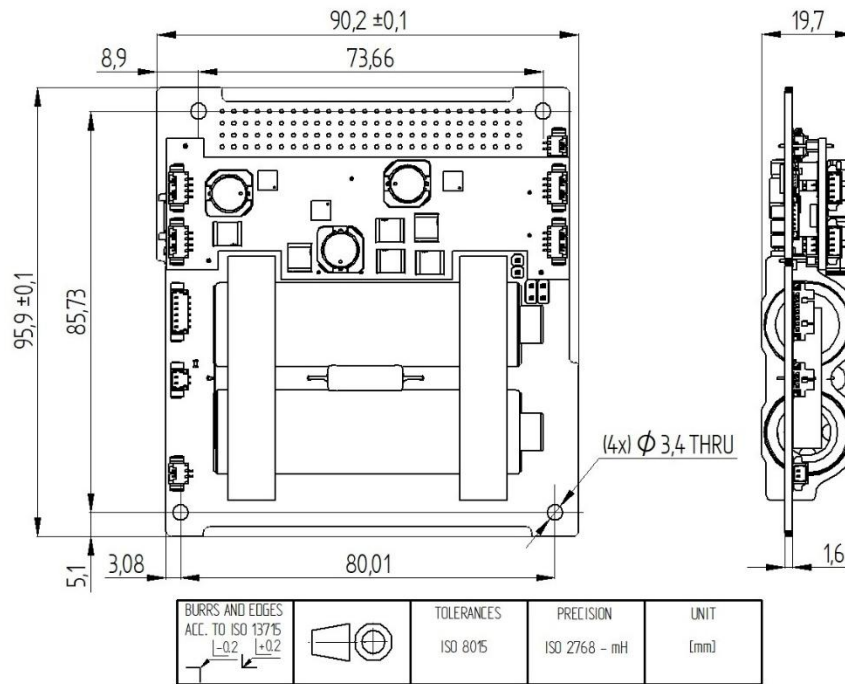

Figure 3-5: Mechanical interface of the Amun 1U PSU module

4 DELIVERABLES

Table 4-1: Deliverables

| Type | Item | Note |
|-----------------|--|---|
| Mechanical Part | 4 pcs of standoffs F+M | to protect H1H2 connector |
| Wiring | 3 pcs of RBF and deployment switch cable | Molex PicoBlade 51021-0200 ~15cm open-ended |
| Wiring | EGSE cable | Molex PicoBlade 51021-0600 ~15cm terminated to female 2.54mm header |
| Wiring | Debug cable | (Molex PicoLock 503764-0601) ~15cm terminated to female 2.54mm header |
| Documentation | Interface Control Document | |
| Support | Engineering support: 1 hour | |

5 RELATED PRODUCTS

You may also be interested in:

- [RA Solar panels](#)
- [1-16U CubeSat Platforms / Complete Mission](#)

6 DISCLAIMER

Spacemanic shall not be liable for any damages, losses, delays, or other consequences arising from improper use, unauthorized modifications, or incompatibility of the product with other systems, even in cases where these products are deployed in demanding environments such as satellite or space applications. The product is designed for specific use according to the technical specifications outlined in the official documentation, and the company is not responsible for any issues arising from usage beyond this scope.

The company is also not liable for damages caused by external factors that cannot be predicted or controlled, including but not limited to infrastructure failures, space conditions (e.g., radiation, microgravity), natural disasters, human error, unauthorized third-party interference, or unplanned changes in regulatory or legal requirements.

By using the product, the user acknowledges awareness of the risks associated with its use in satellite and space applications and accepts full responsibility for the correct deployment and use of the product.